

Steering and Visualization

Enabling Technologies for Computational Science

Helen Wright



THE UNIVERSITY OF HULL

CompSci07

Hull Immersive Visualization Environment

- £0.8M original Science Research Investment Fund (SRIF) input
- Aims to provide range of visualization facilities, depending on application requirements
- In-house HPC
- Further investment into HPC from SRIF2
- Opened (officially...) September 2004
- University-wide facility, adjunct to Department of Computer Science



Motion capture
and rigid body
tracking



Active stereo PowerWall™
- rear projected



Haptic
feedback



64 CPU dual core
Opteron cluster
with Myrinet
interconnect



Passive stereo
- front projected



Personal
immersion



Visualization



Filter – to subsample, smooth, interpolate
Map – data features to geometry attributes
Render – the geometry visible on-screen

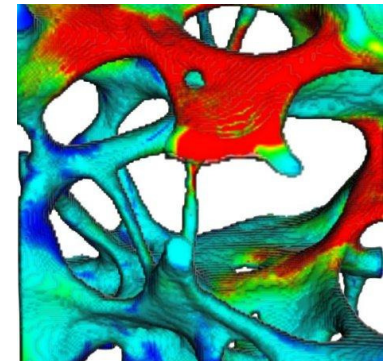

Visualization



Visualization



Visualization and Steering

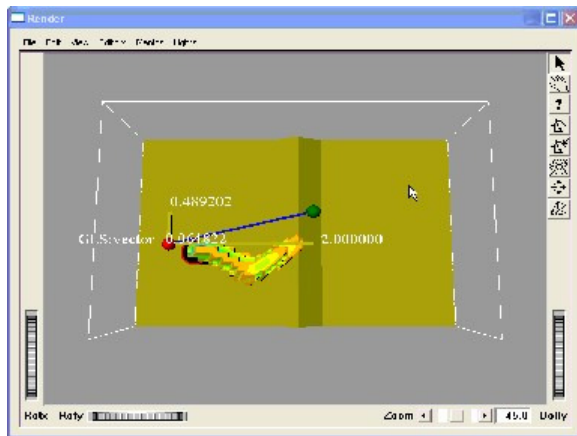
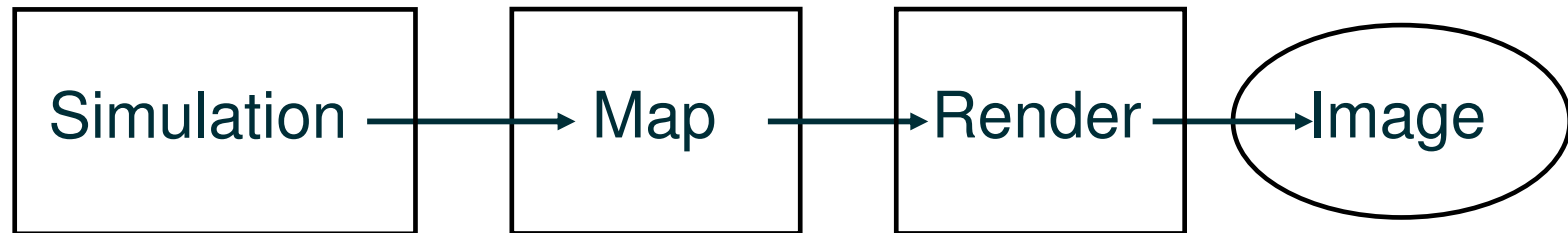

Mechanisms

- Code instrumentation – examples: GRASPARC, RVSLIB, RealityGrid, gViz ... sometimes called application-level steering ...
- ... as opposed to job-level steering – examples: gridMonSteer, Cactus (legacy support) ...



Aims – Parameter Investigation

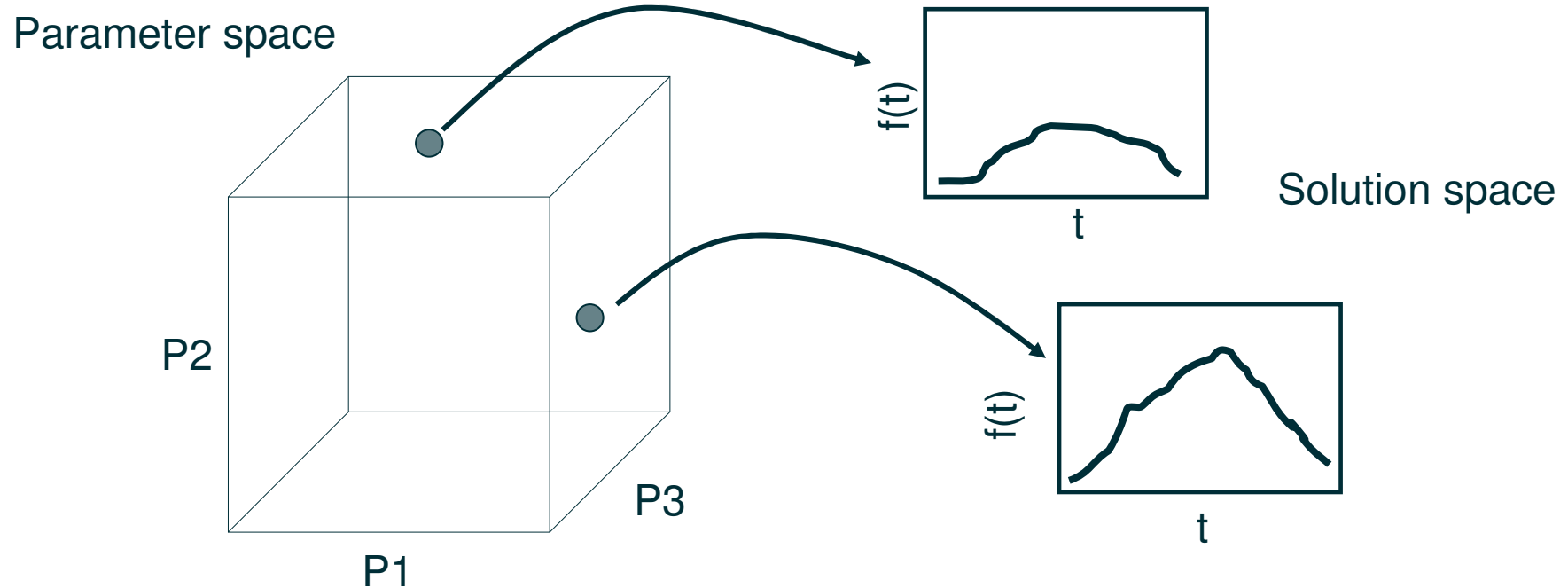

Parameter space \equiv domain of fitness measure (implicit or explicit) e.g.
Experiment-theory correspondence
Quality of designed artefact



Aims – What-if Investigation

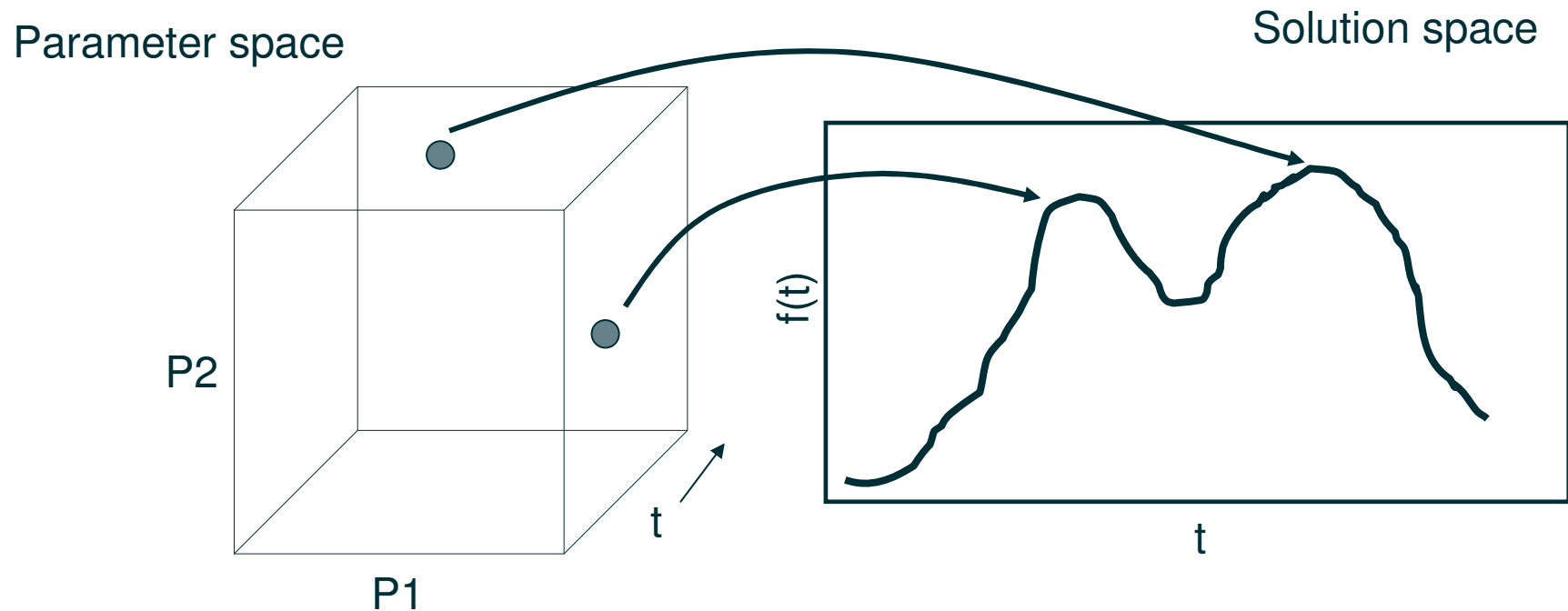

In conjunction with roll-back, leads naturally to the concept of history tree / checkpoint tree

Distributed Pipeline

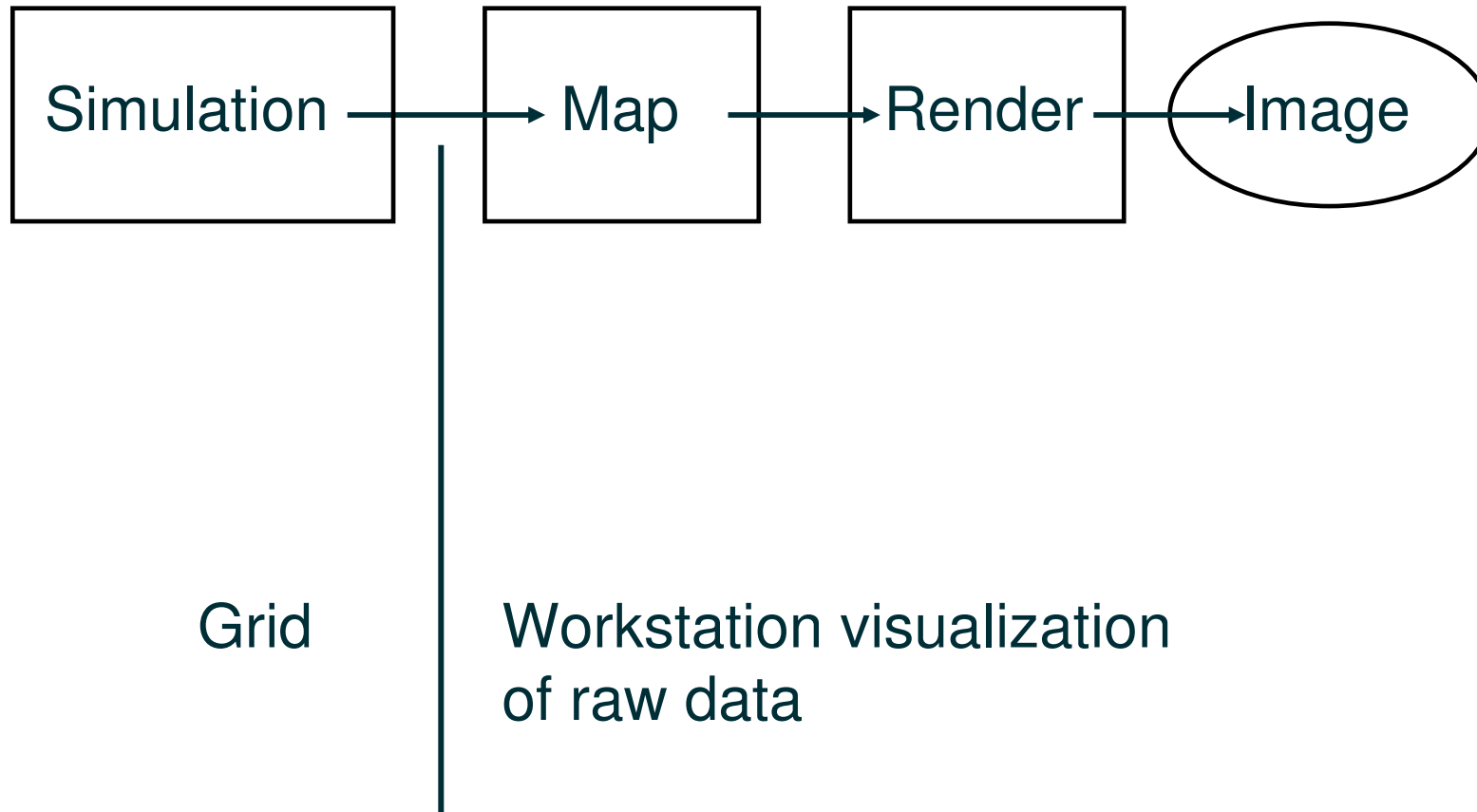

Distributed Pipeline

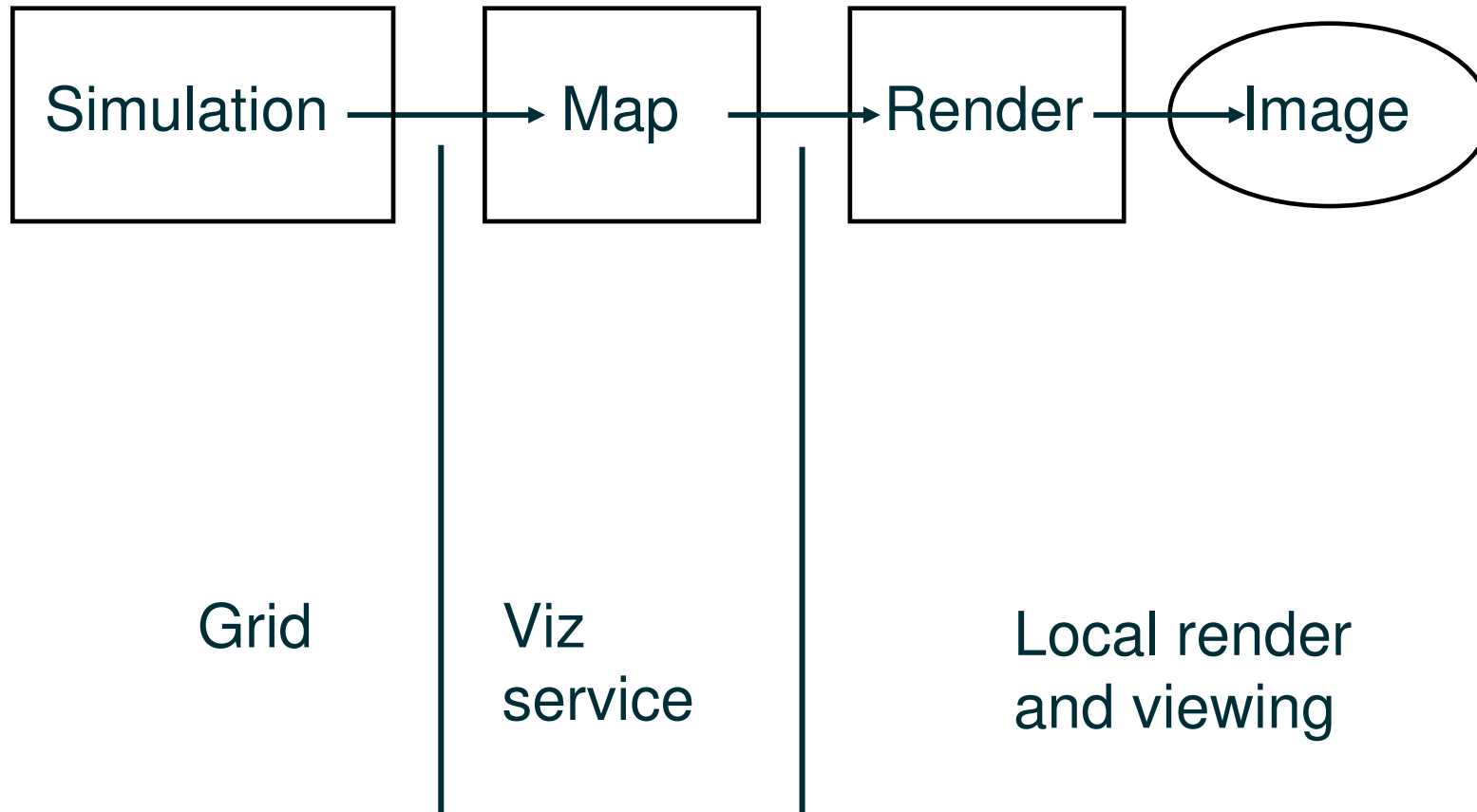

Distributed Pipeline

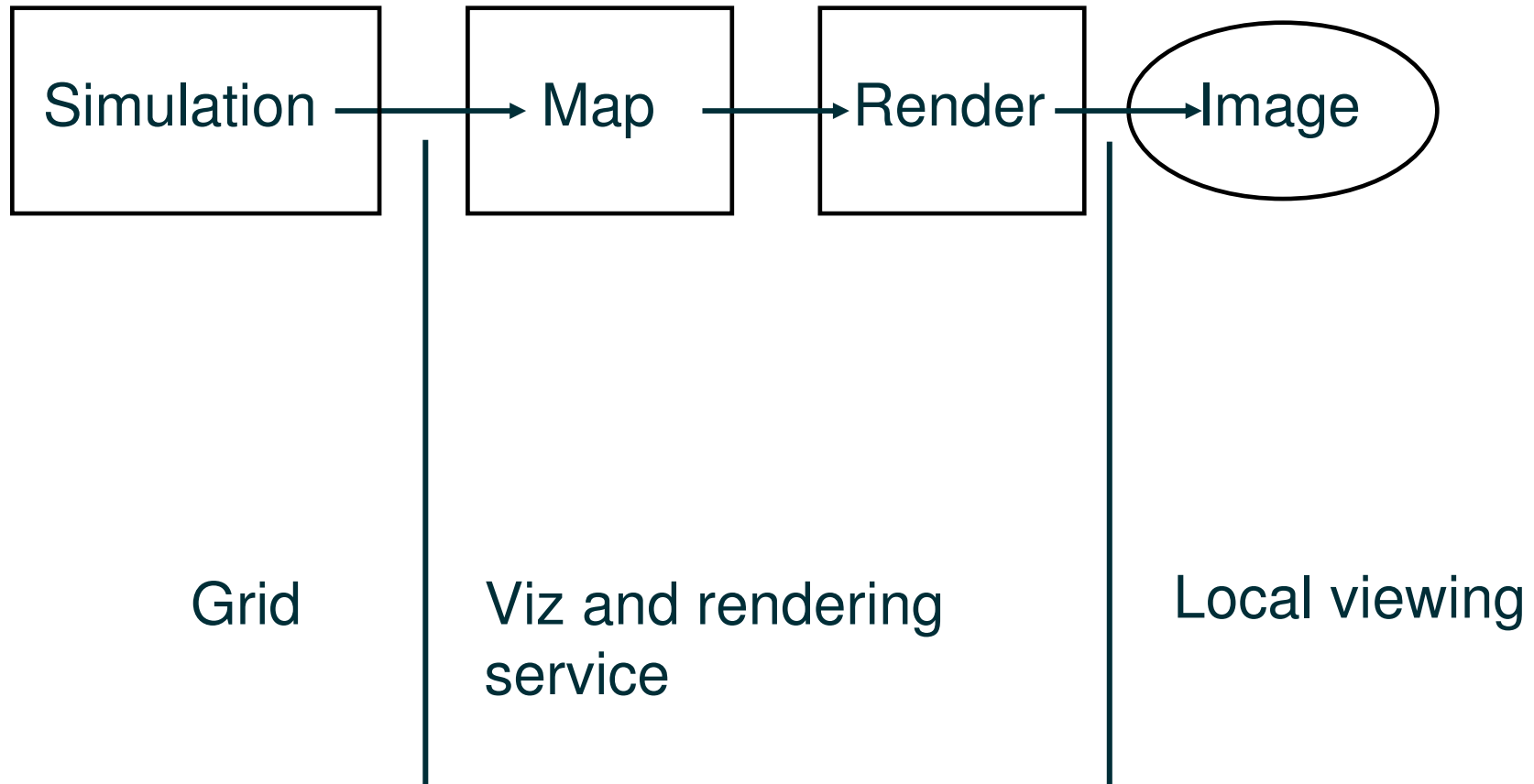

Challenge for HPC

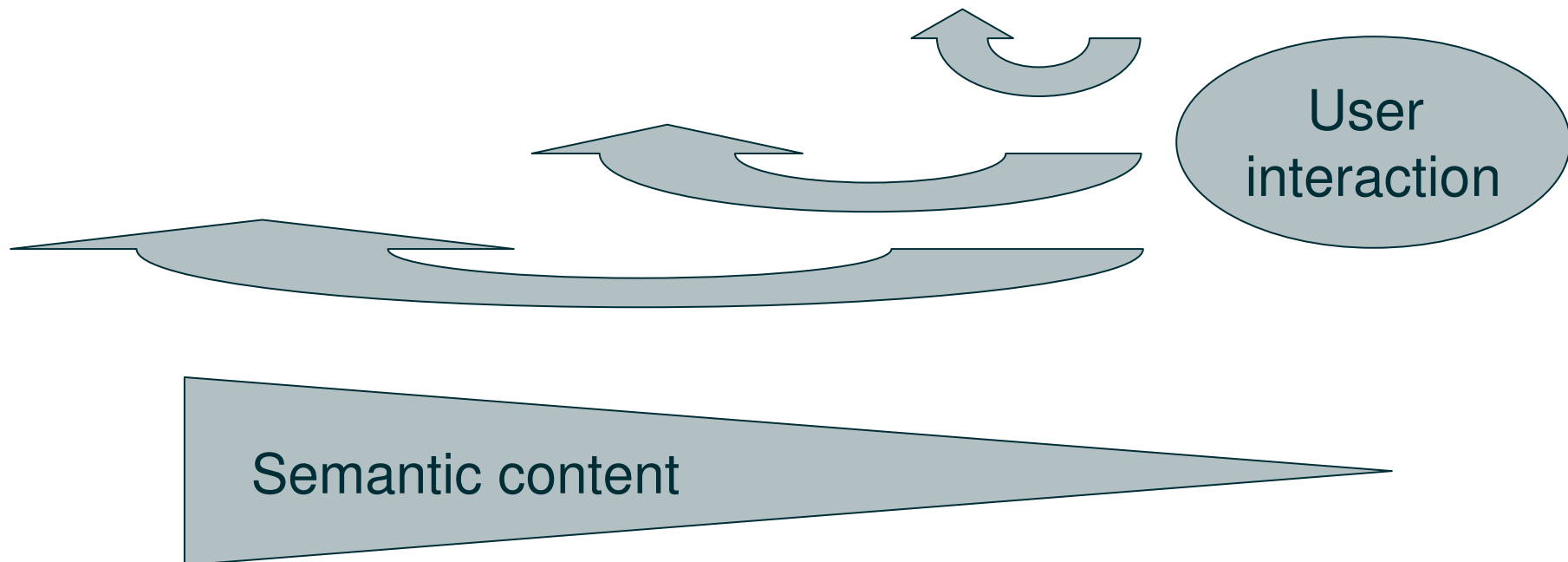
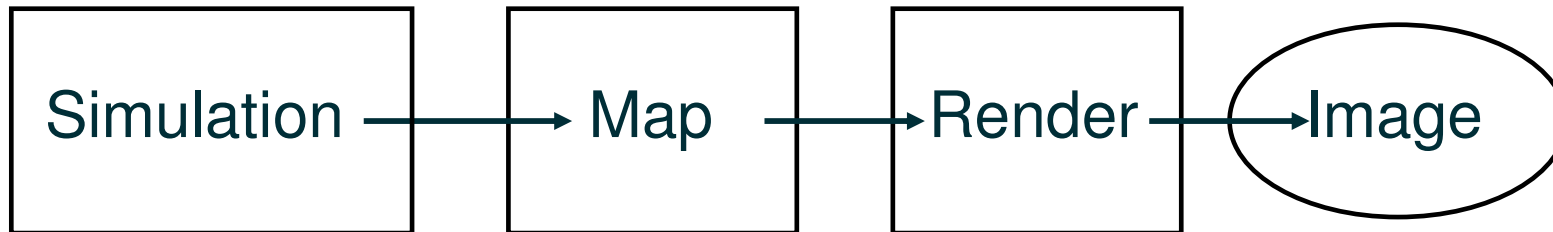

S

M

R

I

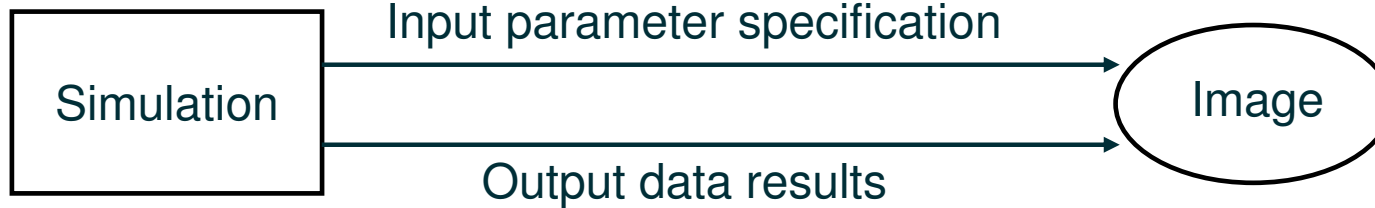

- Multi-Purpose Image Interaction (MPII)
- Doesn't try to invert the pipeline
- Generic parameter types ...
 - > Positional
 - > Scalar
 - > Vector
- ... assume specific roles on delivery to the simulation
- In conjunction with gViz, has implemented collaborative, image-based steering of remote simulation

Chatzinikos and Wright, VDA03; Wood and Wright, AHM05



S

M

R

I

- e-Viz – Advanced Environment for Enabling Visual Supercomputing
- Integrates steering and transmission of rendered images, uncompressed or encoded (JPEG, PNG, RLE ...)
- Multiple servers and clients; clients can switch viz streams
- Client independence from remote renderers
- Deployment entails instrumenting the viz app, much as RealityGrid and gViz instrument a steering app

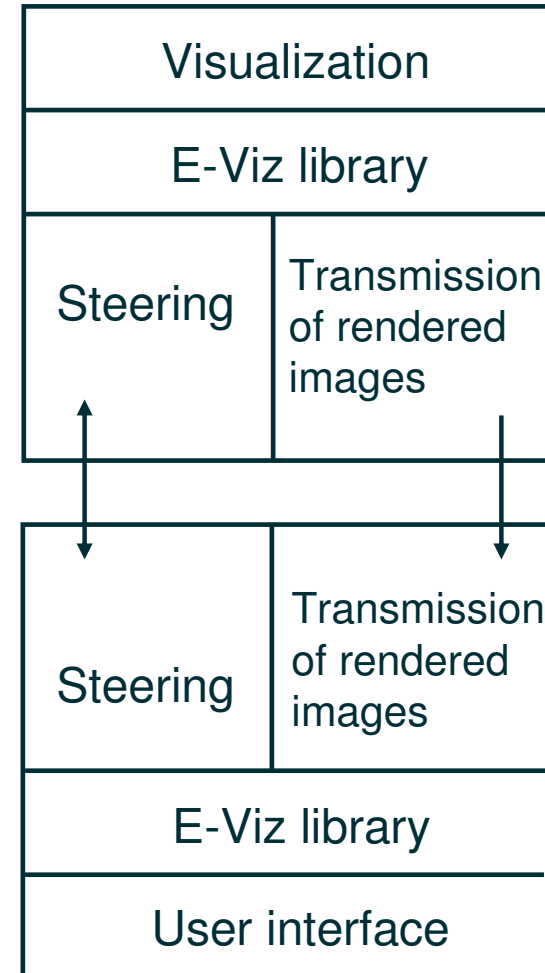

Brooke and Riding, CompuSteer@OGF20; Riding et al, AHM05





- Resource-Aware Visualization Environment (RAVE), RealityGrid
- Requires awareness in terms of network and machine load
- Collaborative
- High-end viz hardware ↔ PDA
- “Active” client can draw for itself
- “Thin” client accepts visual drawn off-screen by render server (RAVE terms)

Grimstead et al, AHM05; Holmes and Kawalsky, AHM06



Managing *Input* Device Diversity

- Ontological approach – formal collection of inter-referenced taxonomies
- Supports semantic reasoning

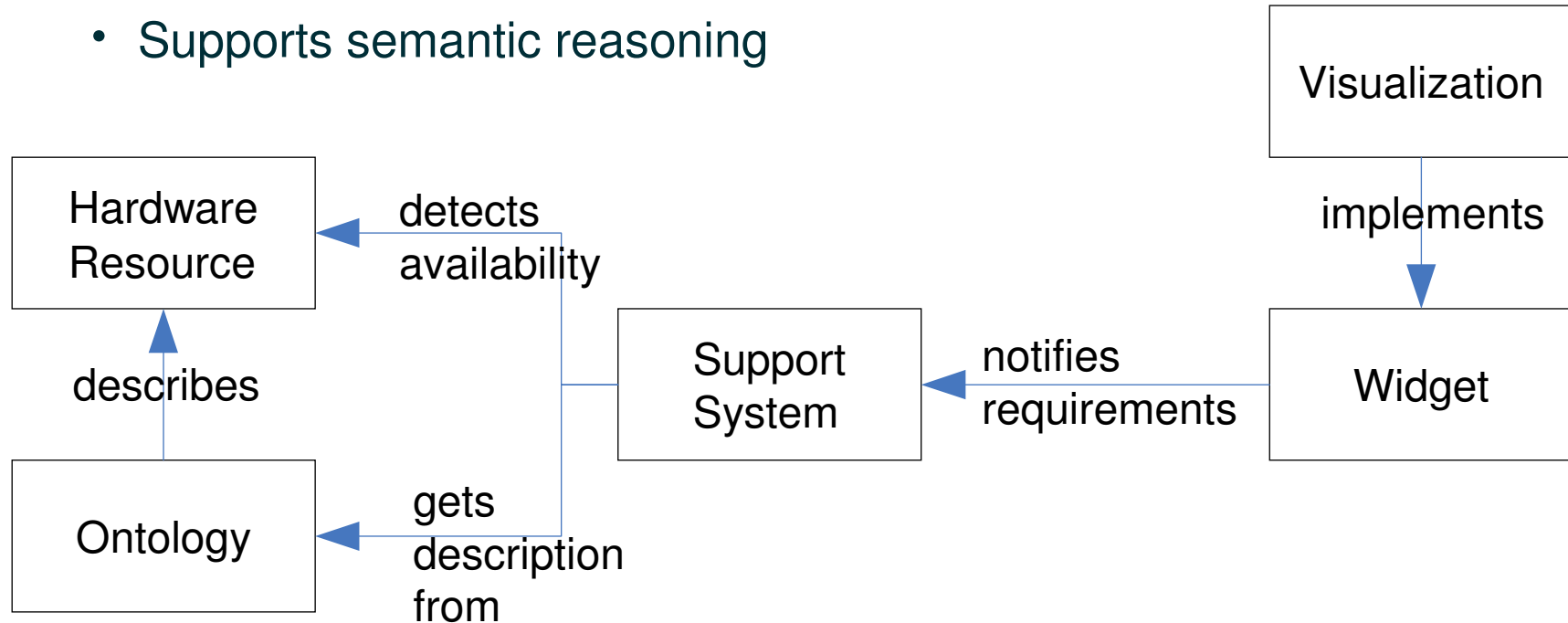

Potter and Wright, LNCS4323; Grimstead and Potter, CompuSteer 1st workshop



Example

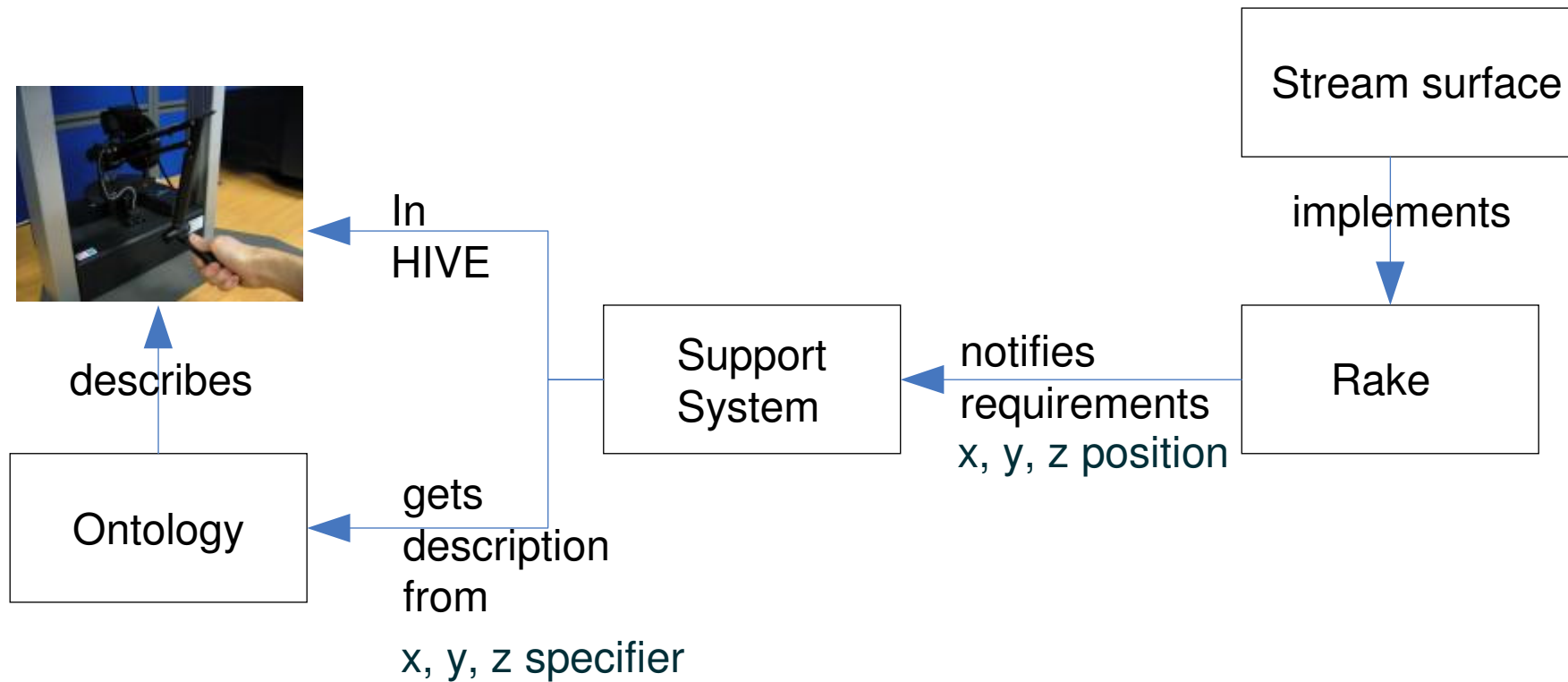

Example

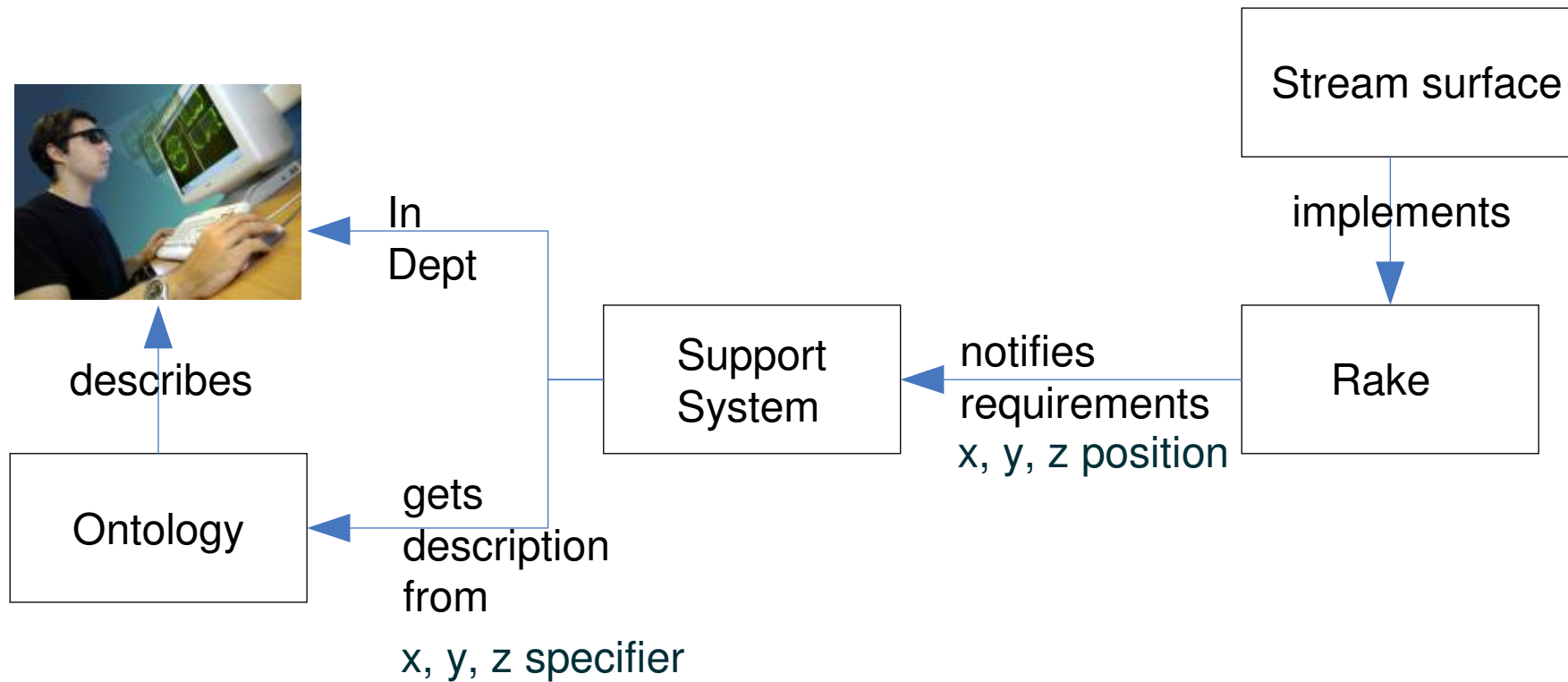

User Perspectives – CompuSteer@OGF20

- It's too HARD! More specifically:
 - > APIs are software-specific, software dependent and/or machine dependent
 - > Operating through firewalls
 - > Contract employment of many IT staff → short-termism
 - > Short lifespan of hardware and software compared with solution implementation
 - > Problematic infrastructure for providing large-scale scientific code support
 - Research funding pressures
 - Who should write code? Who should pay for this?
 - > Standardisation
 - Different user types may need different levels of API
 - Different adapters linking to different middlewares
 - Potential for use cases → API demonstrators



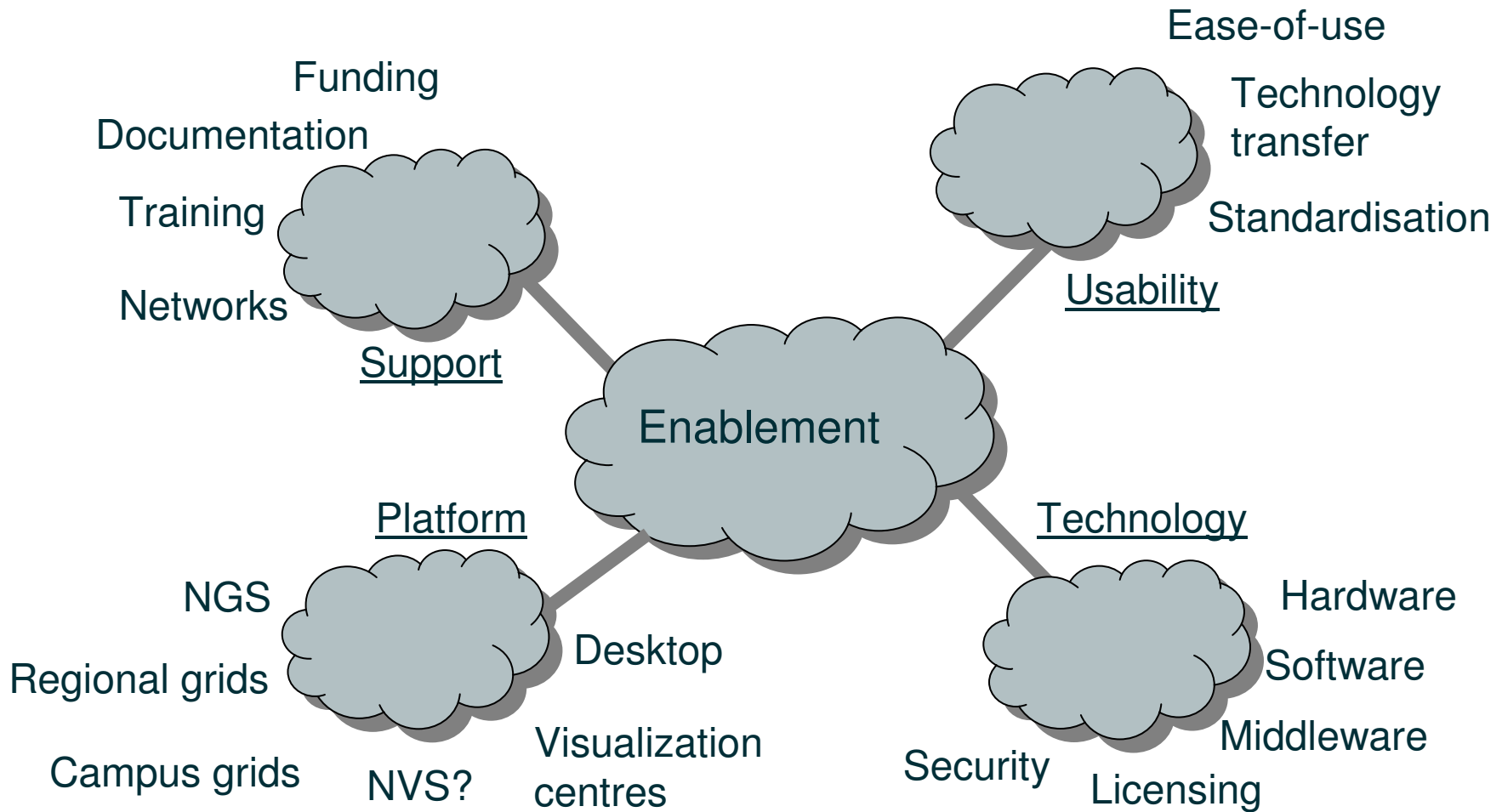

SWOT for Viz/Steering - Technology

- Strength

- > Viz hardware developments

- Opportunity

- > New science

- Weakness

- > Expensive, centralised

- Threat

- > Insufficient technology transfer

- > Users continue to 'make-do' on desktop



SWOT for Viz/Steering - Platforms

- **Strength**

- > Steering APIs compatible/under investigation for production grids

- **Weakness**

- > Batch queuing ('are we there yet' syndrome)
- > Need tunnelling to access child nodes

- **Opportunity**

- > Possible NVS – user requirements gathering

- **Threat**

- > Different character to compute and data
 - Local facilities
 - Local expertise
 - User involvement



SWOT for Viz/Steering - Usability

- Strength

- > Steering APIs mature enough to consider standardisation

- Opportunity

- > Timely – SAGA-RG/WG activities within Open Grid Forum

- Weakness

- > Needs use cases
- > Chicken-and-egg syndrome (but have to start somewhere!)

- Threat

- > Might still be too hard for some users



SWOT for Viz/Steering - Support

- Strength

- > Variety of funding sources
 - SRIF
 - BTG
 - HPC development
 - ...

- Weakness

- > 'Initiative-itis'
- > Equipment-orientated, or pump-priming focus

- Opportunity

- > fEC changing the 'low price culture'

- Threat

- > Current approach sustains short-termism
- > Some users need support/resources *before* getting funded



Networks

- VizNET – UK National Visualization Network (JISC-funded) – Loughborough-led
 - > knowledge dissemination
 - > resource sharing
 - > **training**
- CompuSteer – EPSRC-funded network – Hull-led
 - > **travel grants** for collaborative work
 - > workshop series – **next event 21 Sept 2007, HIVE**
 - > skills matrix

**** Joint venture: possible computational steering course for 2007 ****



References and Information

- AHM0*n* – All Hands Meetings
www.allhands.org.uk/200n/proceedings/index.html
- VDA0*n* – Visualization and Data Analysis, SPIE
electronicimaging.org/program/0n/conferences/index.cfm
- LNCS*nnnn* – Lecture Notes in Computer Science Vol *nnnn*
www.springer.com/content/105633
- vizNET – UK Visualization Support Network
www.viznet.ac.uk
- CompuSteer – EPSRC Network in Computational Steering
www.compusteer.hull.ac.uk
- CompuSteer@OGF20 – 20th Open Grid Forum workshop
www.ogf.org/gf/event_schedule/index.php?id=678
www.ogf.org/gf/event_schedule/index.php?id=782



Acknowledgements

- **HIVE**
 - > Roger Phillips, Director
 - > Emma-Jane Alexander, Coordinator
 - > James Ward, Research Fellow
 - > Mike Bielby, Research Officer
- **Software**
 - > James Ward
 - > Guillaume Emont
 - > George Sias
 - > Jean-Alain Grunhec
 - > Fotis Chatzinikos
 - > Richard Potter
- **Case studies**
 - > Hull Centre for Medical Engineering and Technology
 - > Shipham Valves Ltd
 - > IRIS Explorer test data suite
 - > School of Computing, University of Leeds
- **Video footage**
 - > Kevin Burden, Cascade Multimedia Interactive Training
 - > Mike Johnson, Dog Day Technology Services
 - > Emma-Jane Alexander
 - > James Ward
 - > Richard Potter

